

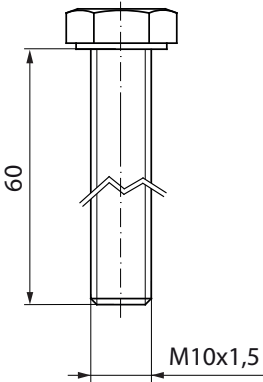



CEMBRE ELECTRICAL PERMANENT CONTACT FOR RAIL WEB TYPE AR66SA-32

COMPOSED BY:

<p>FIXING SCREW</p> <p>UNI EN ISO 4017</p>  <p style="text-align: center;">Stainless steel A4-80 galvanized</p>	<p>AR266-16.5-1 COPPER BUSH</p>  <p style="text-align: center;">Electrolytic copper annealed tin plated</p>	<p>ø10,5x20 FLAT WASHER (2 pcs)</p> <p>UNI EN ISO 7089</p>  <p style="text-align: center;">Stainless steel A4-80</p>	<p>M10x1,5 AUTO-LOCK NUT</p>  <p style="text-align: center;">Stainless steel A4-80</p>
---	--	--	---

NOTE:

The AR66SA-32 contact is suitable to be used on:
 30 ÷ 32 mm web thickness rail
 13,5 ÷ 14,5 mm holes diameter.

INSTALLATION TOOLING:

Cembre Hydraulic tools HTEPF family.

First issue	04.02.25	Drawing N°	Dimensions in mm
Modifications	A	Description changed for Copper bush 03.03.25	* Spanner A/F
	B		
	C		
		V12619	



CEMBRE S.p.A
 Via Serenissima, 9
 25135 Brescia (Italy)
 Ph. +39 03036921
 ufficio.vendite@cembre.com
 sales@cembre.com
 www.cembre.com

